

ARMSTRONG - STEAM & ENGINEERING

FROM CONCEPT TO CONCLUSION

PRODUCT DATA SHEET

ISSUED 2/99

DESCRIPTION

FORGED BRASS SOLENOID VALVE. NORMALLY CLOSED.
CAN BE MOUNTED IN ANY POSITION.
SUITABLE FOR WATER, AIR, OIL OR GAS.

MAXIMUM / MINIMUM WORKING DIFFERENTIAL PRESSURES BY FLUID TYPE.

	10	15	20	25	32	40	50
WATER	20-1000 KPA	20-1000 KPA	20-1000 KPA	20-1000 KPA	50-500 KPA	50-500 KPA	50-500 KPA
AIR	20-1000 KPA	20-1000 KPA	20-1000 KPA	20-1000 KPA	50-700 KPA	50-700 KPA	50-700 KPA
OIL	20-1000 KPA	20-1000 KPA	20-1000 KPA	20-1000 KPA	50-500 KPA	50-500 KPA	50-500 KPA

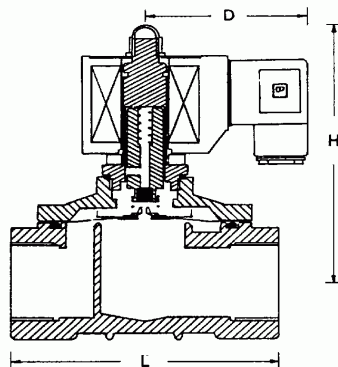

SIZE	L	H	D	CV	KG	PART NAME	MATERIAL	OPTIONAL
10	70	100	50	2.4	0.9	BODY	BRASS	
15	70	100	50	4.5	0.9	BONNET	BRASS	
20	73	102	50	8.6	1.0	DIAPHRAGM	NBR	VITON
25	93	106	50	12	1.8	COIL	DIN	
32	125	140	58	24	3.2	DISC	NBR	VITON
40	125	140	58	28	3.5	SPRING	304 S/S	
50	167	170	58	48	5.4	SLEEVE	304 S/S	

ALL DIMENSIONS ARE IN MM AND ARE APPROXIMATE ONLY IF CRITICAL PLEASE CONFIRM