

ARMSTRONG - STEAM & ENGINEERING

FROM CONCEPT

TO CONCLUSION

Brisbane - Sydney - Melbourne - Perth

Phone: 1300 136 486

Fax: 1300 136 487

Email: sales@armstrongsteam.com.au

Web: www.armstrongsteam.com.au

The current version of this document is located at
www.armstrongsteam.com.au/sds/300c.pdf

PRODUCT DATA SHEET

PRODUCT # SEP-300C (CARBON STEEL) / SEP-300A (316 STAINLESS STEEL)

ISSUED 01/07

DESCRIPTION

“Y” STRAINER WITH FLANGED ENDS TO ANSI 150# RF.
 SCREENS TO SUIT YOUR APPLICATION. FINE MESH TO 37 MICRON.
 CAN BE SUPPLIED WITH BLOWDOWN CONNECTIONS.
 ANSI 300 AND ANSI 600 CONNECTIONS ARE ALSO AVAILABLE.

COLD WORKING PRESSURE : 1965 KPA

SATURATED STEAM PRESSURE : 1035 KPA

MAX TEMPERATURE :

425 DEG C

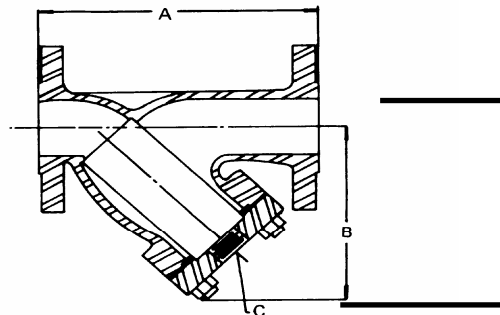

E
 for Screen
 Removal

SIZE	A	B	BD	E	KG	PART NAME	MATERIAL	OPTIONAL
15	125	65	OPT.	125	4			
20	140	76	OPT.	125	6			
25	189	86	OPT.	125	7	BODY	WCB - A216	CF8M-316
40	192	108	OPT.	178	8	CAP	WCB - A216	CF8M-316
50	219	146	1/2"	185	13	SCREEN	304	316
65	260	171	1"	250	23	STUD	B7	304 / 316
80	295	203	1-1/4"	275	25	NUT	2H	304 / 316
100	365	235	1-1/2"	320	30	GASKET	NON ASBES	PTFE
125	448	305	2"	450	62			
150	473	340	2"	510	76	STRAINERS BELOW 50MM		
200	619	422	2"	600	113			
250	663	489	2"	730	170			
300	772	584	2"	795	240			

ALL DIMENSIONS ARE IN MM AND ARE APPROXIMATE ONLY IF CRITICAL PLEASE CONFIRM