

# ARMSTRONG - STEAM & ENGINEERING

FROM CONCEPT TO CONCLUSION

Brisbane - Sydney - Melbourne - Perth

Phone: 1300 136 486

Fax: 1300 136 487

Email: sales@armstrongsteam.com.au

Web: www.armstrongsteam.com.au

This document is located at [www.armstrongsteam.com.au/sds/049.pdf](http://www.armstrongsteam.com.au/sds/049.pdf)

## PRODUCT DATA SHEET

PRODUCT # ASE-049

ISSUED 06-04

### DESCRIPTION

BRONZE SWING CHECK VALVE - MEDIUM PATTERN  
SUITABLE FOR HORIZONTAL OR VERTICAL UP FLOWS.  
CAN BE USED ON WATER, CONDENSATE OR LOW PRESSURE STEAM.

COLD WORKING PRESSURE : 1400 KPA

SATURATED STEAM PRESSURE : 900 KPA

MAX TEMPERATURE :

260 DEG C

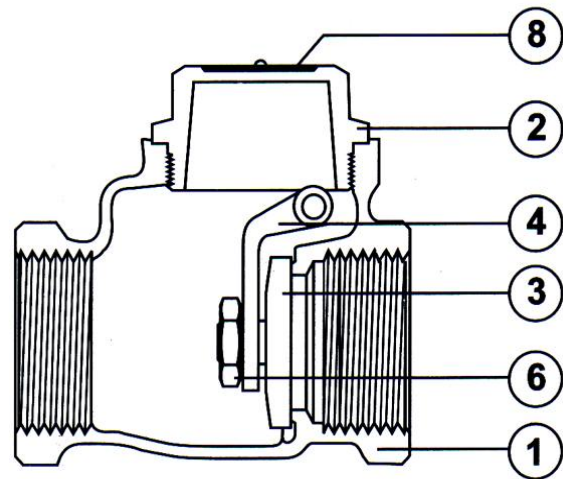
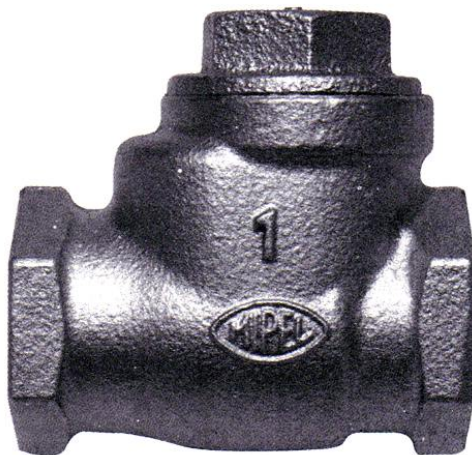

| SIZE | A   | B   | KG  | PART # | NAME     | MATERIAL  |
|------|-----|-----|-----|--------|----------|-----------|
| 15   | 62  | 40  | 0.3 |        |          |           |
| 20   | 67  | 45  | 0.4 | 1      | BODY     | BRONZE    |
| 25   | 78  | 52  | 0.5 | 2      | CAP      | BRONZE    |
| 32   | 92  | 58  | 1.2 | 3      | DISC     | BRONZE    |
| 40   | 102 | 61  | 1.3 | 4      | HANGER   | BRONZE    |
| 50   | 122 | 75  | 2.0 | 6      | DISC NUT | BRASS     |
| 65   | 157 | 89  | 3.5 | 8      | ID TAG   | ALUMINIUM |
| 80   | 170 | 104 | 4.2 |        |          |           |
| 100  | 210 | 124 | 7.6 |        |          |           |

ALL DIMENSIONS ARE IN MM AND ARE APPROXIMATE ONLY IF CRITICAL PLEASE CONFIRM